



The new degree of comfort.™

Rheem *Select*™ Series Upflow/Horizontal Gas Furnaces

**W801T (Upflow/Horizontal) Series
Models with Input Rates
from 50 to 125 kBTU
(80% A.F.U.E.†)**



- 80% residential Gas Furnace CSA certified
- 3-way multi poise design UF / HZ
- 7 Segment LED all units
- Direct spark ignition —for reliability and longevity
- Heat exchanger is removable for improved serviceability. Aluminized steel construction provides maximum corrosion resistance and thermal fatigue reliability.
- Solid doors provide quiet operation
- Low profile 34" cabinet ideal for space constrained installations
- Blower shelf design – serviceable in all furnace orientations

- Hemmed edges on cabinets and doors
- 1/4 turn door knobs for tool less access
- Integrated Controls board features dip switches for easy system set up
- QR code for quick access to product information from your smart phone or tablet
- Constant torque electrically commutated motor
- Cabinet air leakage less than 2% at 1 inch H₂O when tested in accordance with ASHRAE standard 193

†A.F.U.E. (Annual Fuel Utilization Efficiency) calculated in accordance with Department of Energy test procedures.





TABLE OF CONTENTS

| | |
|---|-----|
| Standard & Optional Equipment | 3 |
| Model Features/Physical Data & Specifications | 4 |
| Model Number Identification | 5 |
| Dimensional Data | 6-7 |
| Blower Performance Data | 8 |
| Accessories | 9 |
| Limited Warranty | 10 |





PATENTED HEAT EXCHANGER

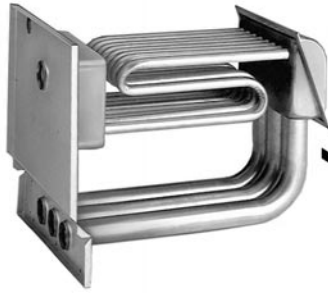

DRAFT INDUCER MOTOR



IN-SHOT BURNERS

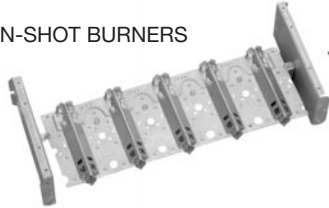

DIRECT SPARK IGNITOR

INTEGRATED
FURNACE
CONTROL

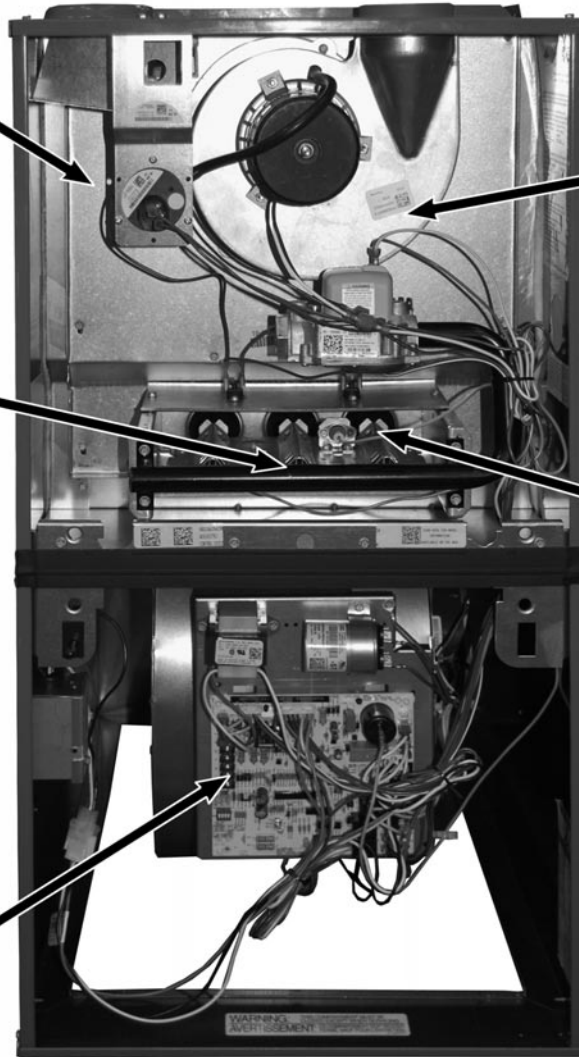
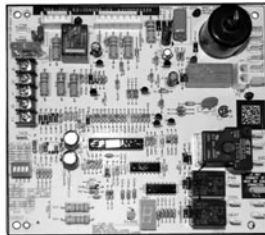

STANDARD EQUIPMENT

Completely assembled and wired; induced draft; pressure switch; redundant main gas control; blower compartment door safety switch; solid state time on/time off blower control; limit control; manual shut-off valve, pressure regulator for natural and L.P. (propane) gas; transformer; direct drive multi-speed blower motor. Furnaces are equipped with cooling/heating relay and transformer (40VA) ready for air conditioning applications. (Please note: a thermostat is not included as standard equipment.) Flame sensor diagnostics.

OPTIONAL EQUIPMENT

Side and bottom filter frame assembly. Return air cabinet for all sizes.
NOTE: Furnace is not listed for use with fuels other than natural or L.P. (propane) gas.

The complete terms of limited and other warranties are available at our sales office, or through local installer.

All models can be converted by a qualified Rheem distributor or local service dealer to use L.P. (propane) gas without changing burners. Factory approved kits must be used to convert from natural to L.P. (propane) gas and may be ordered as optional accessories from a Rheem parts distributor.

For L.P. (propane) operation, refer to Conversion Kit Index Form.

NOTE: For natural and L.P. (propane) gas models, direct spark ignition is 100% safety lockout type.

WARNING

THIS FURNACE IS NOT APPROVED
OR RECOMMENDED
FOR USE IN MOBILE HOMES



Model Features

- 80% residential Gas Furnace CSA certified
- 3 way multi poise design UF / HZ
- PlusOne™ Diagnostics — 7 Segment LED all units
- PlusOne™ Ignition System – DSI for reliability and longevity
- Heat exchanger is removable for improved serviceability. Aluminized steel construction provides maximum corrosion resistance and thermal fatigue reliability.
- Solid doors provide quiet operation
- Low profile 34" cabinet ideal for space constrained installations
- Blower shelf design serviceable in all furnace orientations
- Hemmed edges on cabinets and doors
- 1/4 turn door knobs for tool less access
- Integrated Controls board features dip switches for easy system set up
- QR code for quick access to product information from your smart phone or tablet
- Constant Torque electrically commutated motor

Physical Data and Specifications

| MODEL NUMBERS W801T SERIES | W801TA050314M*A | W801TA075417M*A | W801TA075421M*A | W801TA100521M*A | W801TA125524M*A |
|-------------------------------------|---------------------------------|---------------------------------|---------------------------------|---------------------------------|---------------------------------|
| Input-BTU/Hr [kW] ② | 50,000 [15] | 75,000 [22] | 75,000 [22] | 100,000 [29] | 125,000 [37] |
| Heating Capacity BTU/Hr [kW] ① | 40,000 [12] | 60,000 [18] | 60,000 [18] | 80,000 [23] | 100,000 [29] |
| Heat Ext. Static Pressure [kPa] | .18 [.05] | .20 [.05] | .20 [.05] | .28 [.07] | .28 [.07] |
| Blower (D x W) [mm] | 11 x 6 [279 x 152] | 11 x 7 [279 x 178] | 11 x 7 [279 x 178] | 11 x 10 [279 x 254] | 11 x 10 [279 x 254] |
| Motor H.P.–Speed–PSC Type [W] | 1/2-5 Spd Constant Torque [373] | 1/2-5 Spd Constant Torque [373] | 3/4-5 Spd Constant Torque [560] | 3/4-5 Spd Constant Torque [560] | 3/4-5 Spd Constant Torque [560] |
| Min. Circuit Ampacity | 8 | 8 | 9 | 10 | 11 |
| Min. Overload Protection Device | 15 | 15 | 15 | 15 | 15 |
| Max. Overload Protection Device | 15 | 15 | 15 | 15 | 15 |
| Heating Speed | Med-Low | Med | Med | Med-Low | Med |
| Cooling Speed | High | High | High | High | High |
| Cooling CFM @ Rating Point [L/s] | 1305 [616] | 1402 [662] | 1608 [759] | 1840 [868] | 1934 [913] |
| Max. E.S.P. (In. W.C.) [kPa] | 0.9 [.22] | 0.9 [.22] | 0.9 [.22] | 0.9 [.22] | 0.9 [.22] |
| Temperature Rise Range °F [°C] | 25-55 [13.9-30.6] | 25-55 [13.9-30.6] | 25-55 [13.9-30.6] | 35-65 [19.4-36.1] | 35-65 [19.4-36.1] |
| Max. Outlet Air Temp. °F [°C] | 155 [68.3] | 155 [68.3] | 160 [71.1] | 180 [82.2] | 165 [73.8] |
| Approx. Shipping Weight (Lbs.) [kg] | 110 [50] | 125 [57] | 140 [64] | 140 [64] | 150 [68] |
| AFUE ① | 80.0% | 80.0% | 80.0% | 80.0% | 80.0% |

NOTES: All models are 115V, 60HZ, 1 Ph. Gas connection size for all models is 1/2" [12 mm] N.P.T.

① In accordance with D.O.E. test procedures.

② See Conversion Kit Index Form for high altitude derate.

* S = Standard, X = Low Nox

This furnace does not meet air district requirements of 14 ng/J NOx emissions limit, and thus is subject to a mitigation fee of up to \$450. This furnace is not eligible for the Clean Air Furnace Rebate Program: www.CleanAirFurnaceRebate.com.

This furnace is to be installed for propane firing only in air districts requiring 14 ng/J NOx emission limits. Operating in natural gas mode is in violation of these Rules.

[] Designates Metric Conversions





Model Number Identification

| <u>W</u> | <u>80</u> | <u>1</u> | <u>T</u> | <u>A</u> | <u>075</u> | <u>4</u> | <u>17</u> | <u>M</u> | <u>S</u> | <u>A</u> |
|-----------------------|------------------|------------------|---------------------------|---------------------------------|---|--|--|-----------|---|---|
| R H E E M | 80 = 80% AFUE | 1 = Single Stage | T = Constant Torque | Design Series A = 1st Design | Input BTU/HR 050 = 50,000 075 = 75,000 100 = 100,000 125 = 125,000 | 3 = Up to 3 Ton 4 = 2 ¹ / ₂ to 4 Ton 5 = 3 ¹ / ₂ to 5 Ton | Cabinet Width 14 = 14" 17 = 17.5" 21 = 21" 24 = 24.5" | M = Multi | X = Low NO _x S = Standard | Revision- Marketing (A – First Time Release) |

[] Designates Metric Conversions



Upflow Application

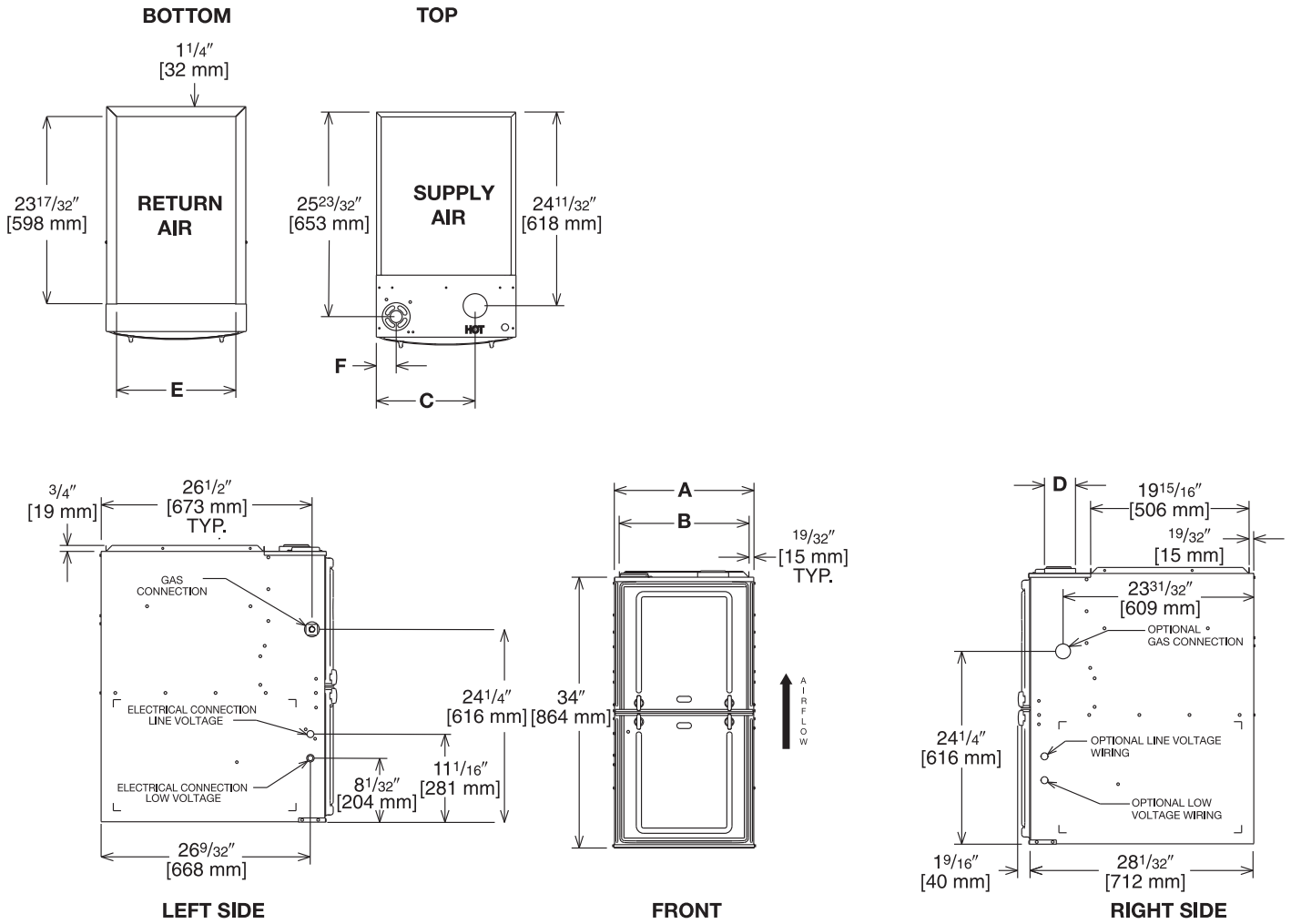

Illustration
ST-A1220-04-00
FIGURE 1

Dimensional Data: Upflow Model

| MODEL W801T- | A | B | C | D | E | F | MINIMUM CLEARANCE (IN.) [mm] | | | | | SHIP WGTS. (LBS.) [kg] | |
|-----------------|--------------|----------------|--------------|---|--------------|------------|------------------------------|--------------------|------|--------|--------|------------------------------|----------|
| | | | | | | | SUPPLY AIR SIDE | RETURN AIR SIDE | BACK | TOP | FRONT | | VENT |
| 050 | 14 [356] | 12 27/32 [326] | 10 5/8 [270] | ① | 11 1/2 [292] | 1 7/8 [48] | 0 | 4 [102] ② | 0 | 1 [25] | 3 [76] | 6 [152] ③ | 110 [50] |
| 075 | 17 1/2 [445] | 16 11/32 [415] | 12 3/8 [314] | ① | 15 [381] | 2 1/2 [64] | 0 | 3 [76] ② | 0 | 1 [25] | 3 [76] | 6 [152] ③ | 125 [57] |
| 100 | 21 [533] | 19 27/32 [504] | 14 1/8 [359] | ① | 18 1/2 [470] | 2 1/2 [64] | 0 | 0 | 0 | 1 [25] | 3 [76] | 6 [152] ③ | 140 [64] |
| 125 | 24 1/2 [622] | 23 11/32 [593] | 15 7/8 [403] | ① | 22 [559] | 2 1/2 [64] | 0 | 0 | 0 | 1 [25] | 3 [76] | 6 [152] ③ | 150 [68] |

NOTES: ① May require a 3" [76 mm] to 4" [102 mm] or 3" [76 mm] to 5" [127 mm] adapter.

② May be 0" [0 mm] with type B vent.

③ May be 1" [25 mm] with type B vent.

Furnaces must be vented in accordance with the National Fuel Gas Code, ANSI Z223.1 and in accordance with local codes.

[] Designates Metric Conversions

Horizontal Application

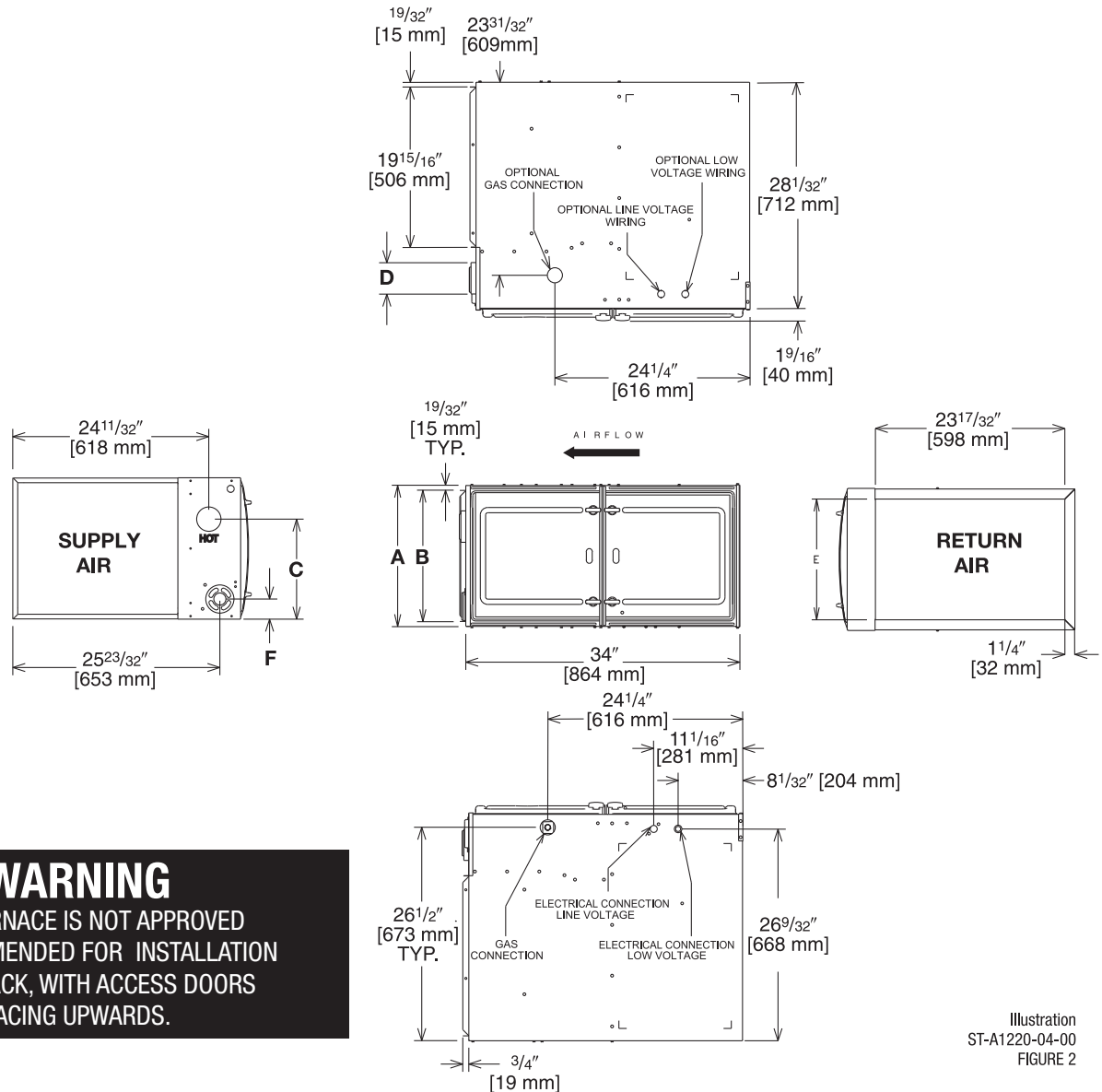

WARNING
THIS FURNACE IS NOT APPROVED OR RECOMMENDED FOR INSTALLATION ON ITS BACK, WITH ACCESS DOORS FACING UPWARDS.

Illustration
ST-A1220-04-00
FIGURE 2

Dimensional Data: Horizontal Model

| MODEL W801T- | A | B | C | D | E | F | MINIMUM CLEARANCE (IN.) [mm] | | | | | | SHIP WGTS. (LBS.) [kg] |
|--------------|--------------------------------------|--|--------------------------------------|---|--------------------------------------|------------------------------------|------------------------------|-----------------|------|--------|--------|-----------|------------------------|
| | | | | | | | SUPPLY AIR SIDE | RETURN AIR SIDE | BACK | TOP | FRONT | VENT | |
| 050 | 14 [356] | 12 ²⁷ / ₃₂ [326] | 10 ⁵ / ₈ [270] | ① | 11 ¹ / ₂ [292] | 1 ⁷ / ₈ [48] | 0 | 4 [102] ② | 0 | 1 [25] | 3 [76] | 6 [152] ③ | 110 [50] |
| 075 | 17 ¹ / ₂ [445] | 16 ¹¹ / ₃₂ [415] | 12 ³ / ₈ [314] | ① | 15 [381] | 2 ¹ / ₂ [64] | 0 | 3 [76] ② | 0 | 1 [25] | 3 [76] | 6 [152] ③ | 125 [57] |
| 100 | 21 [533] | 19 ²⁷ / ₃₂ [504] | 14 ¹ / ₈ [359] | ① | 18 ¹ / ₂ [470] | 2 ¹ / ₂ [64] | 0 | 0 | 0 | 1 [25] | 3 [76] | 6 [152] ③ | 140 [64] |
| 125 | 24 ¹ / ₂ [622] | 23 ¹¹ / ₃₂ [593] | 15 ⁷ / ₈ [403] | ① | 22 [559] | 2 ¹ / ₂ [64] | 0 | 0 | 0 | 1 [25] | 3 [76] | 6 [152] ③ | 150 [68] |

NOTES: ① May require a 3" [76 mm] to 4" [102 mm] or 3" [76 mm] to 5" [127 mm] adapter.

② May be 0" [0 mm] with type B vent.

③ May be 1" [25 mm] with type B vent.

Furnaces must be vented in accordance with the National Fuel Gas Code, ANSI Z223.1 and in accordance with local codes.

[] Designates Metric Conversions

Blower Performance Data

| AIR FLOW PERFORMANCE - (-)801T (Upflow) SERIES MODELS | | | | | | | | | | | |
|---|--|--------------|--|-------------|-------------|-------------|-------------|-------------|-------------|-------------|-------------|
| MODEL | MOTOR H.P. [W] BLOWER SIZE IN [mm] | SPEED TAP | CFM [L/s] AIR DELIVERY EXTERNAL STATIC PRESSURE INCHES WATER COLUMN [kPa] | | | | | | | | |
| | | | 0.1 [.02] | 0.2 [.05] | 0.3 [.07] | 0.4 [.10] | 0.5 [.12] | 0.6 [.15] | 0.7 [.17] | 0.8 [.19] | 0.9 [.22] |
| | | | | | Low | 894 | 775 | 655 | 595 | 533 | 496 |
| (-)801TA050314MSA | 1/2 [373] 11 x 6 [279 x 152] | Med. Lo | 971 | 912 | 875 | 839 | 804 | 758 | 713 | 684 | 644 |
| | | Med | 1117 | 1081 | 1051 | 1024 | 995 | 973 | 938 | 908 | 878 |
| | | Med. Hi | 1326 | 1291 | 1275 | 1240 | 1204 | 1171 | 1144 | 1114 | 1077 |
| | | High | 1440 | 1432 | 1405 | 1382 | 1353 | 1322 | 1305 | 1272 | 1251 |
| | | Low | 1054 | 1014 | 964 | 911 | 860 | 797 | 711 | 657 | 606 |
| (-)801TA075417MSA | 1/2 [373] 11 x 7 [279 x 178] | Med. Lo | 1363 | 1318 | 1275 | 1230 | 1189 | 1129 | 1091 | 1053 | 1012 |
| | | Med | 1447 | 1417 | 1366 | 1329 | 1288 | 1250 | 1215 | 1176 | 1137 |
| | | Med. Hi | 1553 | 1521 | 1478 | 1444 | 1407 | 1372 | 1332 | 1295 | 1264 |
| | | High | 1616 | 1574 | 1547 | 1508 | 1478 | 1438 | 1402 | 1375 | 1341 |
| | | Low | 1176 | 1133 | 1095 | 1048 | 1000 | 951 | 908 | 861 | 810 |
| (-)801TA075421MSA | 3/4 [559] 11 x 7 [279 x 178] | Med. Lo | 1353 | 1312 | 1267 | 1236 | 1186 | 1149 | 1106 | 1079 | 1016 |
| | | Med | 1400 | 1346 | 1307 | 1276 | 1225 | 1181 | 1145 | 1103 | 1069 |
| | | Med. Hi | 1568 | 1537 | 1498 | 1468 | 1433 | 1399 | 1353 | 1320 | 1287 |
| | | High | 1785 | 1775 | 1736 | 1704 | 1673 | 1629 | 1608 | 1573 | 1550 |
| | | Low | 1277 | 1211 | 1164 | 1103 | 1035 | 967 | 861 | 800 | 740 |
| (-)801TA100521MSA | 3/4 [559] 11 x 10 [279 x 254] | Med. Lo | 1556 | 1498 | 1456 | 1409 | 1353 | 1308 | 1254 | 1198 | 1125 |
| | | Med | 1644 | 1597 | 1554 | 1511 | 1463 | 1400 | 1358 | 1304 | 1253 |
| | | Med. Hi | 1879 | 1842 | 1785 | 1729 | 1692 | 1674 | 1621 | 1579 | 1537 |
| | | High | 2071 | 2025 | 1992 | 1948 | 1902 | 1872 | 1840 | 1795 | 1750 |
| | | Low | 1398 | 1338 | 1278 | 1232 | 1177 | 1130 | 1041 | 975 | 909 |
| (-)801TA125524MSA | 3/4 [559] 11 x 10 [279 x 254] | Med. Lo | 1593 | 1546 | 1495 | 1454 | 1414 | 1342 | 1304 | 1251 | 1190 |
| | | Med | 1878 | 1844 | 1807 | 1753 | 1714 | 1675 | 1634 | 1578 | 1536 |
| | | Med. Hi | 2025 | 1967 | 1931 | 1886 | 1856 | 1812 | 1748 | 1721 | 1668 |
| | | High | 2165 | 2124 | 2082 | 2047 | 2012 | 1973 | 1934 | 1894 | 1859 |
| | | Low | 1398 | 1338 | 1278 | 1232 | 1177 | 1130 | 1041 | 975 | 909 |

Note: Bold data is factory heating tap.

Table represents blower performance data WITHOUT filters.

[] Designates Metric Conversions

**BOTTOM RETURN FILTER RACK FOR
UPFLOW APPLICATION: RXGF-CB**

SIDE RETURN FILTER RACK: RXGF-CD

| FILTER RACK FILTER SIZES* INCHES [mm] | | |
|---------------------------------------|--|--|
| MODEL | RXGF-CB (UPFLOW/ HORIZONTAL) | RXGF-CD (UPFLOW) SIDE RETURN |
| W801TA050 | 12 ¹ / ₄ x 25 [311 x 635] | 15 ³ / ₄ x 25 [400 x 635] |
| W801TA075417 | 15 ³ / ₄ x 25 [400 x 635] | 15 ³ / ₄ x 25 [400 x 635] |
| W801TA075421/ W801TA100 | 19 ¹ / ₄ x 25 [489 x 635] | 15 ³ / ₄ x 25 [400 x 635] |
| W801TA125 | 22 ³ / ₄ x 25 [578 x 635] | 15 ³ / ₄ x 25 [400 x 635] |

4" FLUE ADAPTER: RXGW-C01

INDOOR COIL CASINGS

| MODEL NUMBER |
|-----------------|
| RXBC-D14AI |
| RXBC-D17AI |
| RXBC-D21AI |
| RXBC-D21BI |
| RXBC-D24AI |

WARNING: IMPORTANT NOTICE

A SOLID METAL BASE PLATE (SEE TABLE) MUST BE IN PLACE WHEN THE FURNACE IS INSTALLED WITH SIDE AIR RETURN DUCTS. FAILURE TO INSTALL A BASE PLATE COULD CAUSE PRODUCTS OF COMBUSTION TO BE CIRCULATED INTO THE LIVING SPACE AND CREATE POTENTIALLY HAZARDOUS CONDITIONS.

| FURNACE WIDTH IN. [mm] | SOLID BOTTOM KIT NO. | BASE PLATE NO. | BASE PLATE SIZE IN. [mm] |
|--------------------------------------|----------------------------|-------------------|--|
| 14 [356] | RXGB-D14 | AE-61874-01 | 11 ⁵ / ₈ x 23 ⁹ / ₁₆ [295 x 598] |
| 17 ¹ / ₂ [445] | RXGB-D17 | AE-61874-02 | 15 ¹ / ₈ x 23 ⁹ / ₁₆ [384 x 598] |
| 21 [533] | RXGB-D21 | AE-61874-03 | 18 ⁵ / ₈ x 23 ⁹ / ₁₆ [473 x 598] |
| 24 ¹ / ₂ [622] | RXGB-D24 | AE-61874-04 | 25 ⁵ / ₈ x 23 ⁹ / ₁₆ [651 x 598] |

FOR HIGH ALTITUDES:

OPTION CODE FOR HIGH ALTITUDE: U.S.

None required for high altitudes.

HIGH ALTITUDE CONVERSION KITS: U.S.

None required for high altitudes.

80+ HIGH ALTITUDE INSTRUCTIONS

CAUTION: Always follow National Fuel Gas Code (NFGC) guidelines when converting for high altitudes.

High altitude option codes are not required for these models. However, the burner orifice size needs to be recalculated and verified at elevations above 2000 ft. See Installation Instructions for more information.

[] Designates Metric Conversions

GENERAL TERMS OF LIMITED WARRANTY*

Rheem will furnish a replacement for any part of this product which fails in normal use and service within the applicable period stated, in accordance with the terms of the limited warranty.

*For complete details of the Limited and Conditional Warranties, including applicable terms and conditions, contact your local contractor or the Manufacturer for a copy of the product warranty certificate.

PartsFive (5) Years
Heat Exchanger.....Ten (10) Years



The new degree of comfort.™

In keeping with its policy of continuous progress and product improvement, Rheem reserves the right to make changes without notice.

Rheem Heating, Cooling & Water Heating • 5600 Old Greenwood Road
Fort Smith, Arkansas 72908 • www.rheem.com

Rheem Canada Ltd./Ltée • 125 Edgeware Road, Unit 1
Brampton, Ontario • L6Y 0P5



INTEGRATED HOME COMFORT

PRINTED IN U.S.A. 7/20 QG FORM NO. G33-544